

# හෙවෙ මොඩෙල් A

# හෙවෙවල

## QUOTATION/ORDER SHEET

To fill and send



### SHEAVE MODEL A

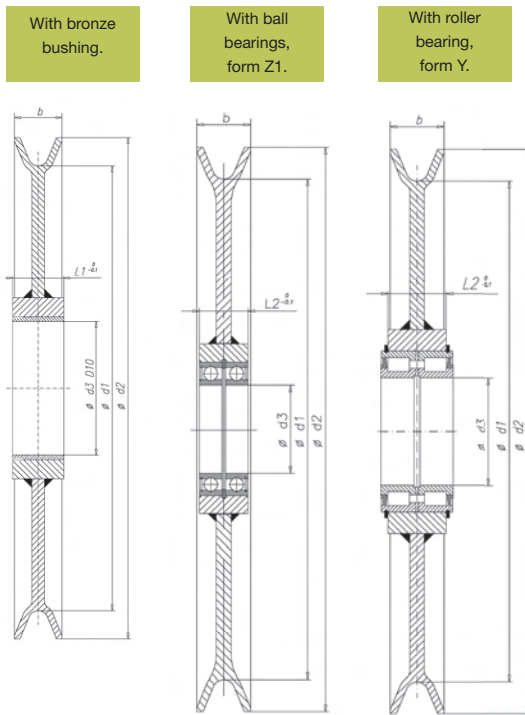

**DATA TO COMPLETE**

\*1- d1 Diam (mm) .....

\*2- Wire diam (mm) .....

\*3- Bearing .....

\*4- Working group (FEM/DIN) .....

\*5- Max. Wire force (KN).....

\*\*6- Wire speed ( m/min ) ..... (15 rpm)

\*\*7- Wire clamp arch ( ° ) ..... (180°)

\*\*8- Wire inclination ( ° ) ..... (4°)

\* Necessary information to prepare an offer.  
 \*\* Defect data, confirm it or indicate the right information.

**OTHER DATA**

\*\* 9- Hardening (HB) ..... (200 - 250 HB)

\*\* 10 - Painting ..... (Primer painting)

**OTHER REQUIREMENTS**

.....

.....

.....

.....

.....

.....

.....

.....

.....

.....