

4 SHEAVES BLOCK AND TACKLE

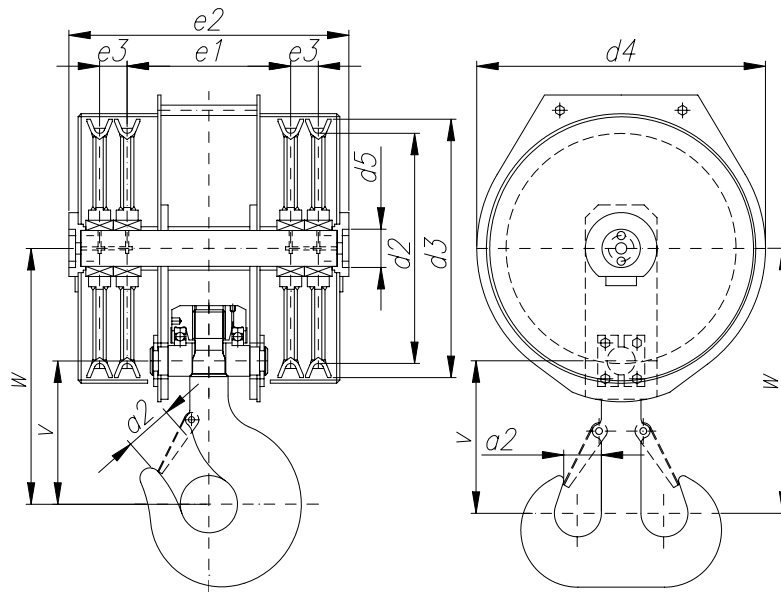

DATA TO COMPLETE

- *1- d2 diameter (mm)
- *2- Wire diameter (mm)
- *3- Working group (FEM/DIN)
- *4- Load on the block (Tn)
- **5- Speed (m/min)
- * 6 - e1 Dimension (mm)
- * 7 - e3 Dimensions (mm)

* Necessary information to prepare an offer.
** Defect data, confirm it or indicate the right information.

OTHER DATA

** 8 - Painting (Primer Painting)

OTHER REQUIREMENTS

.....

.....

.....

.....

.....

.....

.....

.....

.....

.....