

COUPLINGS WITH CONVEX TEETH. Model AGT 11.

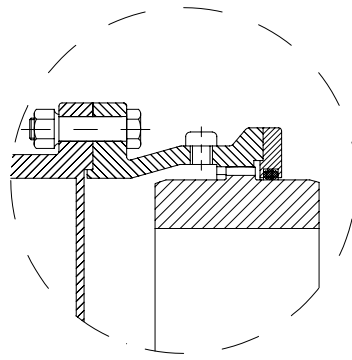

From 280 to 800

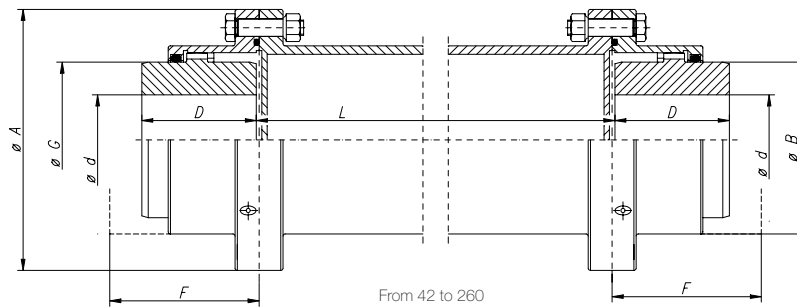

From 42 to 260

DATA TO COMPLETE

- *1- Nominal torque (DaN.m)
- *2- Speed (rpm)
- *3- Working group (FEM/DIN)
- *4- D dimension (mm)
- *5- d diameter (mm)
- *6- L dimension (mm)
- * Necessary information to prepare an offer.

OTHER REQUIREMENTS

.....

.....

.....

.....

.....

.....

.....

.....

.....

.....