

COUPLINGS WITH CONVEX TEETH. Model AGT 10.

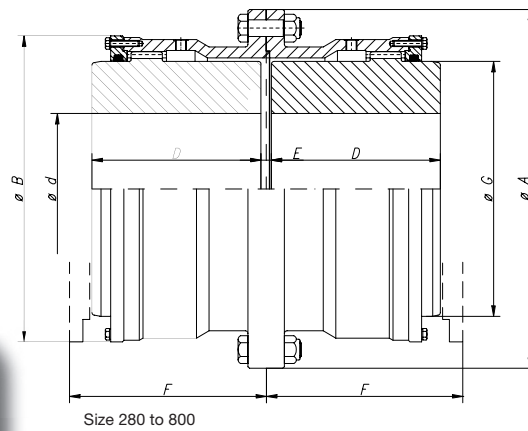
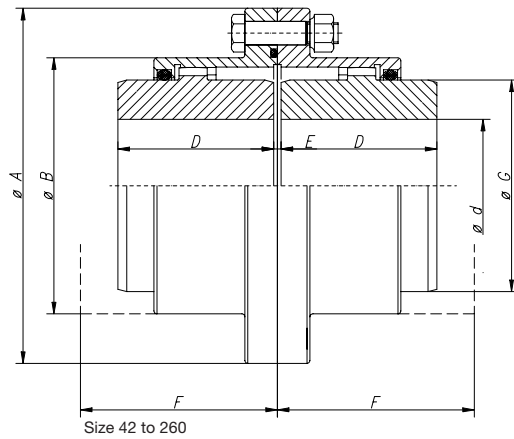

DATA TO COMPLETE

- *1- Nominal torque (DaN.m)
- *2- Speed (rpm)
- *3- Working group (FEM/DIN)
- *4- D Dimen. (mm)
- *5- E Dimen. (mm)
- *6- d Diam. (mm)

* Necessary information to prepare an offer.

OTHER REQUIREMENTS

.....

.....

.....

.....

.....

.....

.....

.....

.....

.....